

Actuator and Sensor Cordset Connection Cable RSM 35-xM/S600

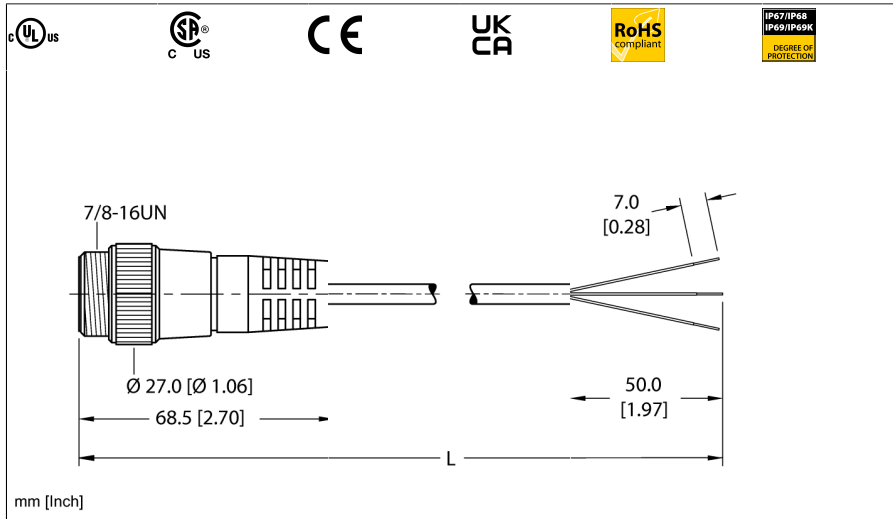

- 7/8" Male, Straight, 3-pin
- Flexible Service Cable
- Yellow CPE jacket, 3X16 AWG
- Sunlight Resistant
- -50 Cold Bend Rating
- Oil Resistant
- Flame Ratings: UL 1060, CSA FT1

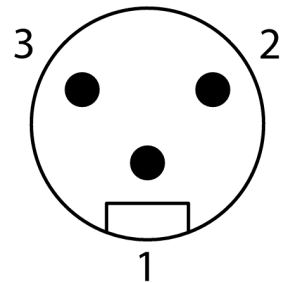

Type	RSM 35-xM/S600
ID	777001355
Connector A	Male, 7/8"-16 UN, Straight
Number of contacts	3
Contact carriers	Plastic, TPU, Black
Connector body	Plastic, TPU, Yellow
Coupling nut	Brass, CuZn, Nickel-plated
Mechanical life	> 100 Mating cycles
Pollution degree	3
Protection class (When coupled)	IP67, IP68, IP69, IP69K
	NEMA: 1, 3, 4, 6P, 12

Circuit Diagram



Cable data	
Cable ID	RF50596
Total number of conductors	3
Cable diameter	Ø 10.31mm
Cable jacket	CPE, Yellow
Conductor diameter	0.12 "
Conductor material	TC (tinned copper)
Conductor insulation material	EPDM
Conductor size	3 x 16 AWG [Similar to 1.50 mm²]
Number of strands x O.D.	65 x 34AWG
Conductor colors	GN/YL, RD/BK, RD/WH
Electrical properties at +20 °C	
Rated voltage	300VV
Current	10AA

Mechanical and chemical properties	
Bending radius (static)	$\geq 5 \times \varnothing$
Bending radius (dynamic)	$\geq 10 \times \varnothing$
UL cold bend rating	-40 °C
Ambient temperature range (static)	-40°C...+105°C°C
Ambient temperature range (dynamic)	5°C...+105°C°C
Temperature range (installation)	-10°C...+105°C °C

Approval

Note

- Flex ratings may be reduced if used in extreme temperatures, exposure to certain chemicals, operating above the rated cycle speed, or operating below the rated cable bend radius.

- We reserve the right to make technical alterations without prior notice.